

Single Roller PSA Sealer

Document List

Section	Description	File Name
	This Document 1 of 1	61374111.FM
Table of Contents	1 of 1	61374310.FM
Operator's Instructions	Pages 1-4	61374010.FM
Maintenance Instructions	Pages 5-6	61374210.FM
Service and Parts Contact	1 of 1	61053911.FM
	Cover and Back	61374410.FM

Single Roller PSA Sealer

Table of Contents

Operator's Instructions - - - - -	1
PSA Sealer Setup - - - - -	2-4
Maintenance Instructions - - - - -	5-6

Single Roller PSA Sealer

Operator's Instructions

These instructions describe the operation of the Single Roller PSA Sealer. Read all instructions before using the PSA Sealer, and keep for future reference.

PSA Sealer Setup

Refer to Figures 1 and 2 for the information below.

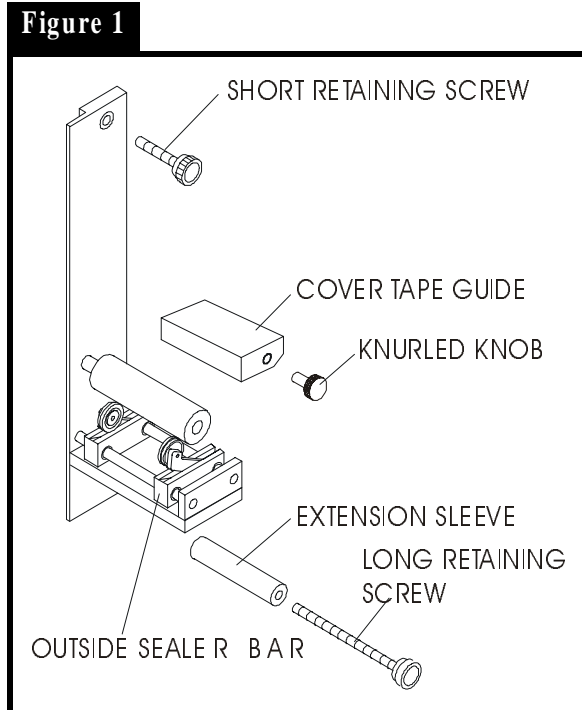

Mount PSA Sealer (Figure 1)

Remove the existing heat sealer and position the PSA sealer in place. Insert the short retaining bolt in the top hole on the sealer, and the long bolt through the extension sleeve into the bottom hole. Tighten the retaining bolts; make sure the sealer is seated squarely.

Install Dummy Plug (Figure 2)

Connect the dummy plug to the sealer connector on the taping machine. The taping machine will not operate properly without this plug installed.

Set Temperature Controllers

Set both temperature controllers at a set point (SP) of 30°C and an alarm value of at least 10. With the dummy plug installed, the temperature controllers will remain constant at a value close to 30°C.

Set Sealer Width (Figure 1)

Sealer width is adjusted by pressing down on the lever holding the sealer wheels and simply sliding the sealer bars inward or outward as needed for the carrier tape being used. It is important to set the width of the sealer AFTER threading the carrier tape through the sealer. The sealer wheels need to be underneath the edges of the carrier tape so that they are pressed against the large roller.

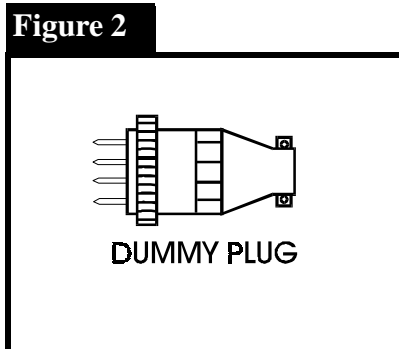

PSA Sealer Setup

Refer to Figure 1 for the information below.

Select Cover Tape Guide (Figure 1)

There is a different cover tape guide for each tape width. These are the same guides used with the interchangeable heat sealers. When changing the sealer width, the cover tape guide must also be changed. To do so, remove the knurled metal knob that secures it in place and slide it straight off. Mount the new cover tape guide once the sealer width has been changed.

Load Tapes into the Sealer

Pull enough cover tape down so about 8" can be laid down on the carrier tape, sticky side down. Press the cover tape onto the carrier tape, so it is centered and running straight. Slide the two tapes under the cover tape guide, through the sealing wheels, and up to the drive sprocket on the left side of the sealer.

Lift the drive sprocket idler wheel up by pressing down on the left side of the idler arm. Move the carrier tape over the teeth on the drive sprocket and align the sprocket holes in the carrier over the teeth. Release the drive sprocket idler wheel. Make sure the teeth have engaged the holes in the tape.

Cover Tape Alignment

Make sure the cover tape is in the tape groove of the cover tape guide.

Check to be sure the tape is started into the tape guide to the left of the drive sprocket. Run tape through the sealer until the alignment of the cover tape to the carrier tape becomes constant. Carefully look at the cover tape to carrier tape alignment, at the point between the sealer and the drive sprocket, to decide whether it needs to be adjusted.

To move the cover tape in relation to the carrier, loosen the knob on the cover tape guide and pull the guide slightly away from the adjustment dial so the dial will turn freely.

PSA Sealer Setup

Refer to Figures 3, 4, and 5 for the information below.

Figure 3

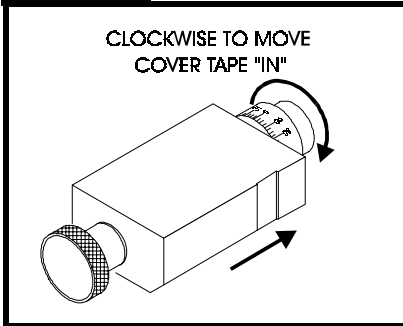

Figure 4

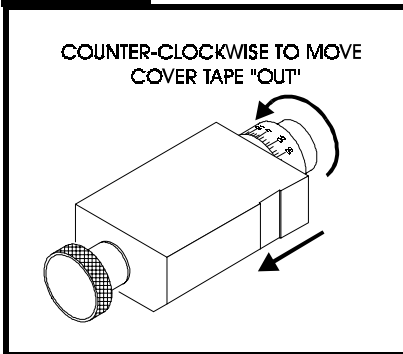
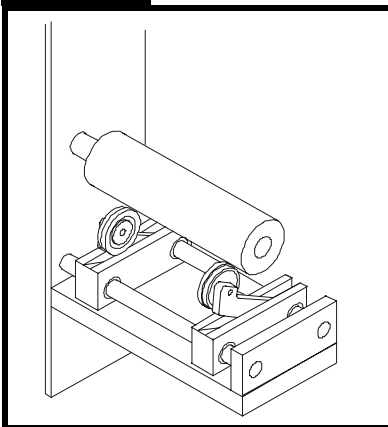

Figure 5



Cover Tape Alignment

Turning the dial clockwise (Figure 3) will move the cover tape closer to the sprocket holes on the inside edge of the carrier (10 divisions on the dial will move the tape .005 inches).

Turning the dial counterclockwise (Figure 4) will move the cover tape closer to the outside edge of the carrier (10 divisions on the dial will move the tape .005 inches).

Push the tape guide back against the dial after the adjustment has been made and tighten the knob. Run the tape out again until the cover tape stops shifting and check the alignment. Repeat this procedure until the proper alignment has been achieved.

Sealer Wheel Alignment (Figure 5)

The small wheels that seal the cover tape to the carrier tape need to be positioned so they will run directly under the sticky portion of the cover tape. Sealer wheels are aligned by pressing down on the lever holding the sealer wheels and simply sliding the sealer bars inward or outward as needed for the carrier tape being used. It is important to align the sealer wheels AFTER threading the carrier tape through the sealer. The sealer wheels need to be underneath the edges of the carrier tape so that they are pressed against the large roller.

Single Roller PSA Sealer

Maintenance Instructions

These instructions describe the maintenance procedures for the Single Roller PSA Sealer. Read this entire manual before performing any maintenance procedures, and keep for future reference.



WARNING

Only qualified persons are allowed to perform maintenance procedures on the PSA Sealer. Any maintenance procedures performed by unqualified persons could cause personal injury.



CAUTION

Only qualified persons are allowed to perform maintenance procedures on the PSA Sealer. Any maintenance procedures performed by unqualified persons could cause damage to the equipment.

Maintenance Instructions

Refer to Figure 6 for the information below.

Single Roller PSA Sealer Maintenance

Clean the residues from the sealer assembly by using a cloth soaked in alcohol.

Using a cotton swab soaked in alcohol, clean between the sealer wheels. Also, clean the entire surface of the large roller and the slide shafts.

Figure 6

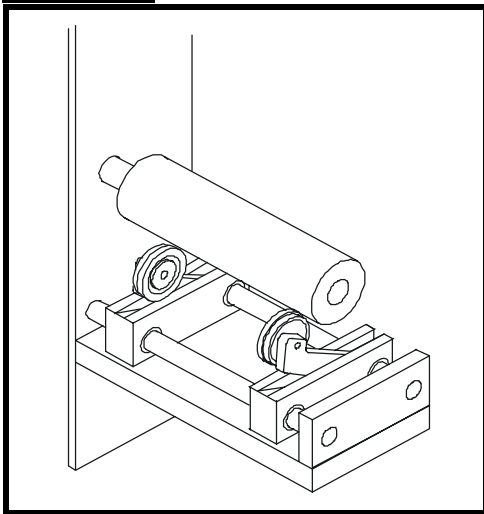

CAUTION

Do not use solvents other than alcohol for cleaning the plastic wheels.



751 Summit Avenue
Mankato, MN USA 56001

www.vtekusa.com

Your questions are important to us. For customer service, please call or write:

Phone: 507-387-2039 Extension 145
Email: vteksvc@gotocrystal.net

Please provide the machine model and serial numbers with all inquiries.

To order spare parts, please call:

Phone: 507-387-2039 Extension 133

For tape and reel supplies, please call:

Phone: 507-387-2039 Ask for CPM Sales

NOTES

Single Roller PSA Sealer Operator's Manual

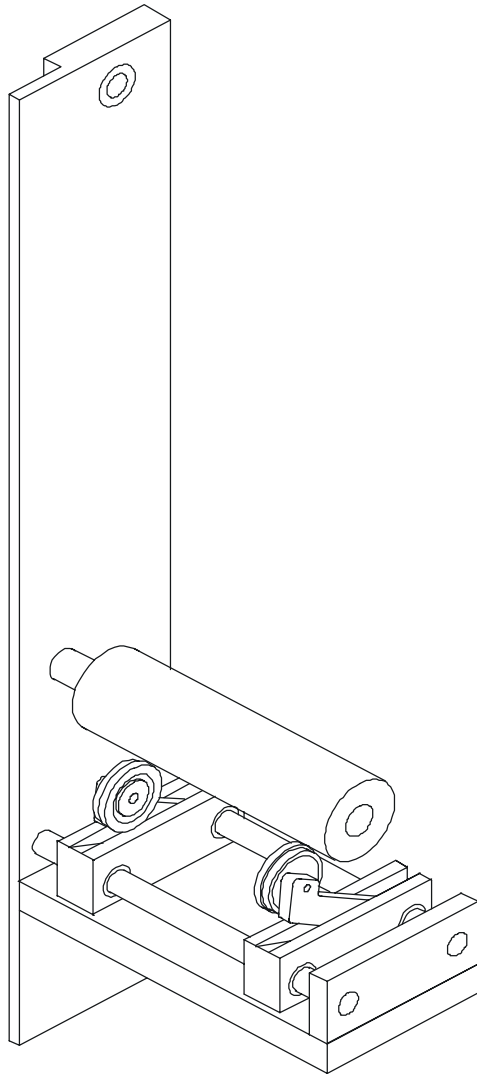



**751 Summit Avenue
Mankato, MN 56002**

(507) 387-2039 FAX: (507) 387-2257

www.VTEKUSA.com
E-Mail: Info@VTEKUSA.com

